

BrokerML

Business Component Framework

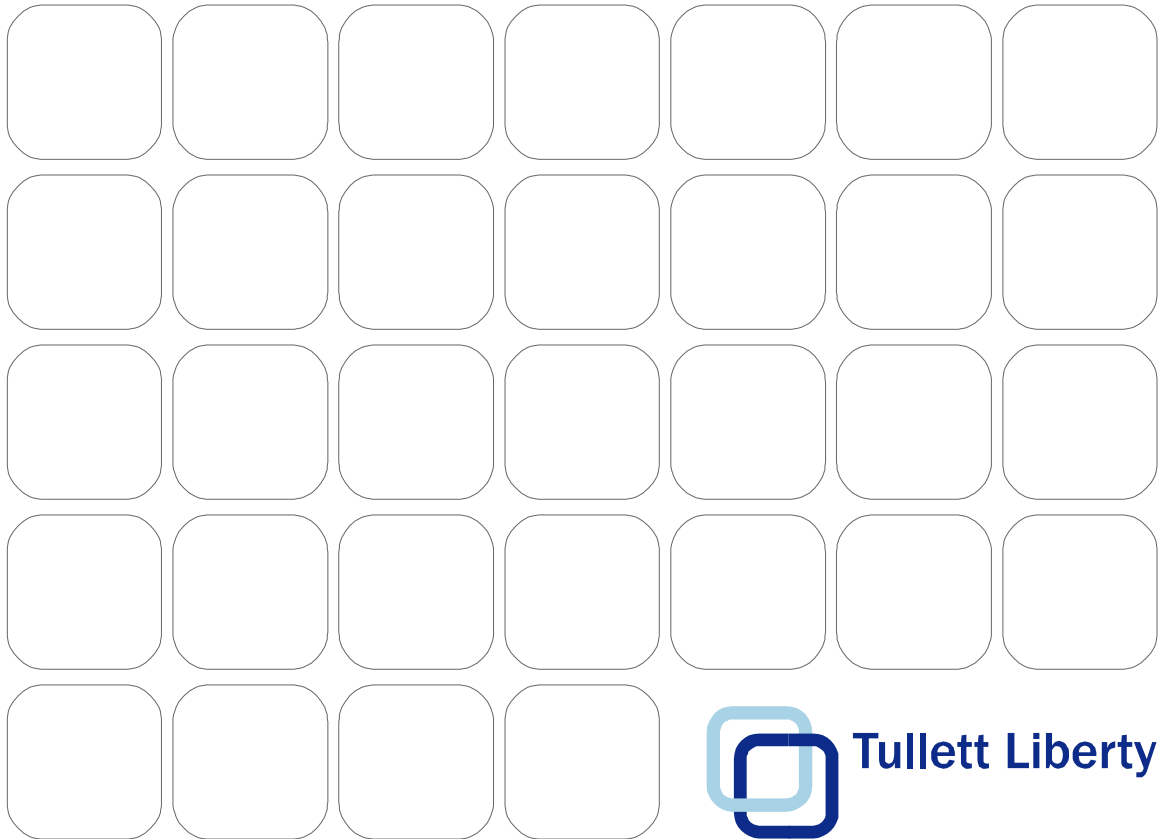

Tullett Liberty

Synopsis

Version: 2.2
Version date: 10th April 2003
Authors: Peter Meekings – Tullett & Tokyo Liberty PLC
Ashutosh Tripathi – Quantum Imagination Limited
With acknowledgements to FpML standards team

Synopsis

This document describes the Tullett business terms and components of the standard vocabulary for exchanging deal, trade and product information– BrokerML. BML is largely based on FpML 2.0 and 3.0 standards with extensions required to support the broking business.

Document Control

Status: Issue
Authorised By:
Distribution: As required

Document History

Version:	Date:	Description:
2.2	31 st March 2003	Document created.
2.2	10 th April 2003	Released for review.
2.2	16 th April 2003	Various corrections after first review.

References

Version:	Date:	Document:	Location
2.2	27 th March 2003	BrokerML - Overview v2.2	???
2.2	28 th March 2003	BrokerML – Coding Schemes v2.2	???
1.1	26 th February 2002	BrokerML - Design Guidelines v1.1	???
1.0	14 th May 2001	FpML 1.0	http://www.fpml.org/spec/2001/1/rec-fpml-1-0-2001-05-14
2.0	10 th February 2003	FpML 2.0	http://www.fpml.org/spec/2003/3/rec-fpml-2-0-2003-02-10
1.0	16 th March 2001	FpML Architecture 1.0	http://www.fpml.org/spec/2001/1/rec-fpml-arch-1-0-2001-03-16

Contents

1	Introduction	5
2	The <i>notification</i> Component.....	6
2.1	The <i>notificationHeader</i> Component	6
	The <i>notificationSTPStatuses/notificationSTPStatus</i> Component	7
3	The <i>parties/party</i> Component	8
	The <i>partyContacts/partyContact</i> Component.....	8
	The <i>communicationMethods/communicationMethod</i> Component.....	8
	The <i>deal</i> Component.....	9
4	The <i>deal</i> Component.....	10
4.1	The <i>dealHeader</i> Component.....	11
	The <i>partyDealIdentifiers/partyDealIdentifier</i> Component.....	11
	The <i>dealDuration</i> Component.....	13
	The <i>dealSTPStatuses/dealSTPStatus</i> Component.....	13
4.2	The <i>trades/trade</i> Component.....	13
4.3	The <i>options/option</i> Component	14
4.4	The <i>additionalPayments/additionalPayment</i> Component	14
	The <i>paymentDate</i> Component	14
4.5	The <i>instructions/instruction</i> Component	15
5	The <i>trades/trade</i> Component	16
5.1	The <i>tradeHeader</i> component.....	17
	The <i>partyTradeIdentifiers/partyTradeIdentifier</i> Component	17
	The <i>tradeSTPStatuses/tradeSTPStatus</i> Component.....	18
	The <i>tradeDuration</i> Component	19
5.2	The <i>options/option</i> Component	19
5.3	The <i>additionalPayments/additionalPayment</i> Component	19
5.4	The <i>instructions/instruction</i> Component	19
6	The <i>options/option</i> Component	20
6.1	The <i>buyerOrgReferences</i> and <i>sellerOrgReferences</i> Components.....	21
6.2	The <i>premium</i> Component	22
6.3	The <i>optionStartDate</i> Component.....	22
6.4	The <i>optionExerciseDate</i> Component.....	22
6.5	The <i>optionExpiryDate</i> Component.....	23
7	The <i>product</i> Component	24

Figures

Figure 1 - Graphical representation of a deal notification	6
Figure 2 - Graphical representation of a notification header	6
Figure 3 - Graphical representation of notification STP status.....	7
Figure 4 - Graphical representation of a party in a transaction.....	8
Figure 5 - Graphical representation of party contact details.....	8
Figure 6 - Graphical representation of communication information	9
Figure 7 - Graphical representation of deal information.....	10
Figure 8 - Graphical representation of a deal header.....	11
Figure 9 - Graphical representation of deal identifiers for parties	12
Figure 10 - Graphical representation of transaction references for parties	12

Figure 11 - Graphical representation of the duration of a deal	13
Figure 12 - Graphical representation of the STP status of a deal.....	13
Figure 13 - Graphical representation of a set of trades	13
Figure 14 - Graphical representation of a set of options on the terms of a transaction.....	14
Figure 15 - Graphical representation of the additional payments for a transaction	14
Figure 16 - Graphical representation of the payment date for a transaction	14
Figure 17 - Graphical representation of the date adjustments for a transaction.....	15
Figure 18 - Graphical representation of textual instructions for a transaction.....	15
Figure 19 - Graphical representation of a trade	16
Figure 20 - Graphical representation of a trade header.....	17
Figure 21 - Graphical representation of a trade header.....	17
Figure 22 - Graphical representation of the STP status of a trade	18
Figure 23 - Graphical representation of the duration of a deal	19
Figure 24 - Graphical representation of a set of options on the terms of a transaction.....	19
Figure 25 - Graphical representation of the additional payments	19
Figure 26 - Graphical representation of textual instructions for a transaction.....	19
Figure 27 - Graphical representation of option information	20
Figure 28 - Graphical representation of organisation references.....	21
Figure 29 - Graphical representation of option premium	22
Figure 30 - Graphical representation of option start date	22
Figure 31 - Graphical representation of option exercise date	23
Figure 32 - Graphical representation of option expiry date	23
Figure 33 - Graphical representation of a product	24

Copyright © 2003 by companies in the Tullett Liberty Group.

This document contains information proprietary to companies in the Tullett Liberty Group, and may not be reproduced, disclosed or used in whole or part without the express written permission of the Tullett Liberty Group.

1 Introduction

BrokerML has been defined in the form of a business component framework that include main business entities that constitute a wholesale financial transaction. These are represented in XML based markup designed following the [BrokerML - Design Guidelines v1.1](#).

The main business components in the BML business component framework are

- Notification – This component contains information about notification of a deal that has been brokered by the Tullett group.
- Deal - This component contains economic and other information about a deal brokered by the Tullett group.
- Trades/Trade - This component contains economic and other information about individual trades within a deal brokered by the Tullett group.
- Product - This component contains economic and other information about individual products that have been traded within a deal brokered by the Tullett group.

These components are defined in more detail in the following sections.

2 The *notification* Component

The *notification* is the top-level component for notification of a transaction in BrokerML. This notification has details about a deal that has been done between two or more parties.

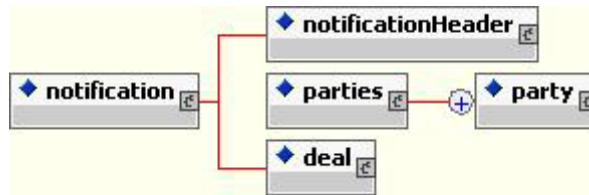

Figure 1 - Graphical representation of a deal notification

A BrokerML *notification* contains three components:

- General details about the notification – *notificationHeader*.
- Details about two or more parties involved in the notification – *parties/party*.
- Details about the various components of transactions that constitute a deal between two or more parties – *deal*.

2.1 The *notificationHeader* Component

The *notificationHeader* has the common information regarding a notification.

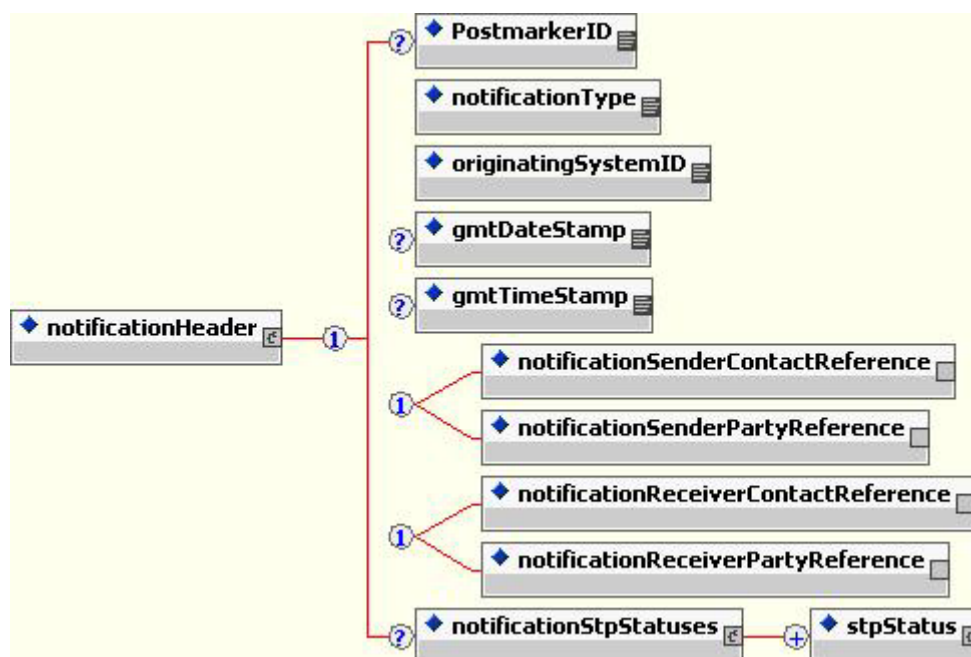

Figure 2 - Graphical representation of a notification header

It contains

- A notification identifier – *PostmarkerID*.
- The type of notification – *notificationType*.
- An identifier of the originating system – *originatingSystemID*.
- The stamped date of the notification – *gmtDateStamp*.
- The stamped time of the notification – *gmtTimeStamp*.

- Reference to the party or party contact sending the notification, defined elsewhere in the notification – *notificationSenderPartyReference* or *notificationSenderContactReference*.
- Reference to the party or party contact receiving the notification, defined elsewhere in the notification – *notificationReceiverPartyReference* or *notificationReceiverContactReference*.
- A notificationSTPStatuses container for
 - Zero or more STP status flags related to the notification – *stpStatus*.{{haven't changed this style - yet}}

The notificationSTPStatuses/notificationSTPStatus Component

The *notificationSTPStatus* contains the Straight Through Processing status of a notification.

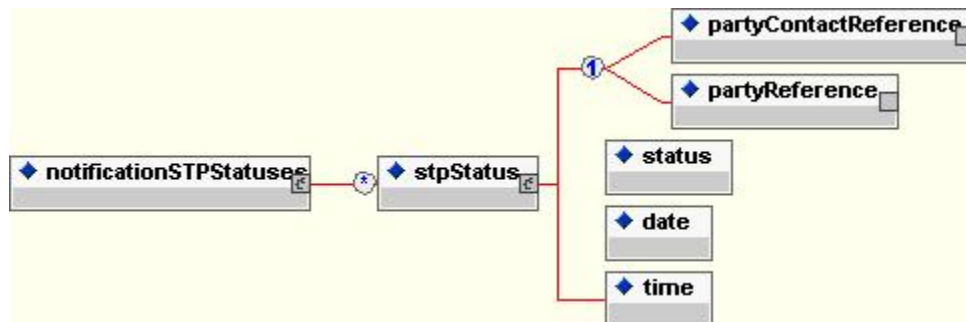

Figure 3 - Graphical representation of notification STP status

It holds information about

- References to the party to which the notification STP status relates to – *partyContactReference* or *partyReference*.
- The STP status itself – *status*.
- The date and time of the status – *date* and *time*.

3 The *parties/party* Component

The *parties/party* component contains details about two or more organisations or people that have entered into a financial contract described in the *deal* component.

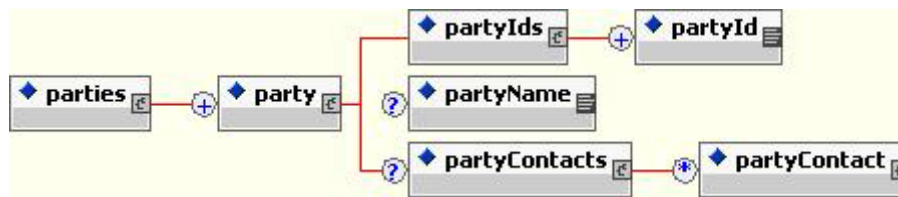

Figure 4 - Graphical representation of a party in a transaction

The *party* component holds information about organisations and people involved in a financial transaction. The two mandatory parties are to be the principal organisations undertaking the transaction and potentially additional third parties such as a broker.

It should be noted that a BML document is not 'written' from the perspective of one particular party, i.e. it is symmetrical with respect to the principal parties. The particular role that a party plays in the trade, e.g. buyer, seller, stream payer/receiver, fee payer/receiver, is modelled via the use of references from the component where the role is identified to the *party* component.

It contains

- A set of one or more identifiers by which the party can be referenced – *partyIds/partyId*.
- An optional name by which the party is known – *partyName*.
- One or more optional contact details for the party – *partyContacts/partyContact*.

The *partyContacts/partyContact* Component

The *partyContact* component holds contact information about people etc. of parties involved in a transaction.

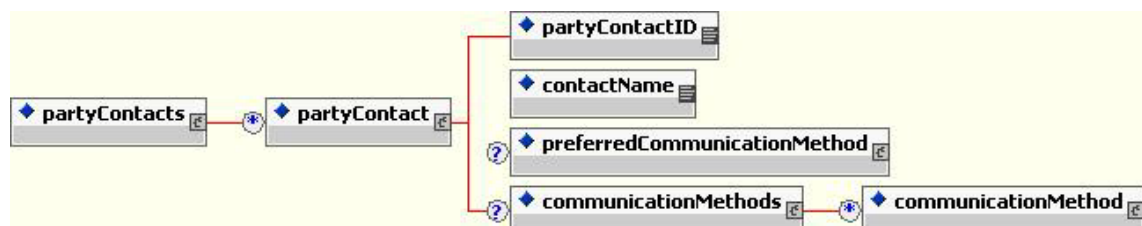

Figure 5 - Graphical representation of party contact details

It contains

- A contact identifier – *partyContactID* for referencing
- The name of the contact – *contactName*
- One preferred and zero or more alternate communication methods – *preferredCommunicationMethod* and *communicationMethods/communicationMethod* *{{theses 2 lines need tweaking}}*

The *communicationMethods/communicationMethod* Component

The *communicationMethod* component contains information about means of communication for a party contact.



Figure 6 - Graphical representation of communication information

It consists of the name of the communication medium and its address in the required format and notation for that medium.

The *deal* Component

The *deal* component contains details about an agreement between two or more parties to enter into a financial contract involving one or more trades. The *deal* element contains all the information required to confirm this agreement.

4 The *deal* Component

A deal is a set of financial transaction contracts entered exchange and agreed between two or more parties. The *deal* component is the top level BML element containing details about such a contract involving one or more trades. The *deal* element contains all the information required to confirm this contract.

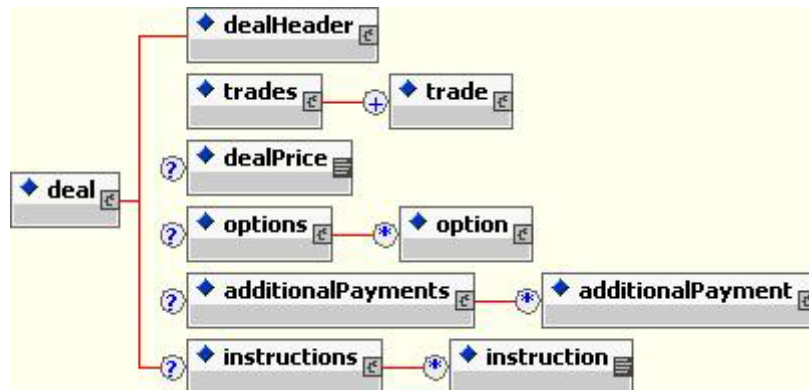

Figure 7 - Graphical representation of deal information

It contains

- A deal header – *dealHeader*.
- One or more trade details – *trades/trade*.
- The optional price of the deal – *dealPrice*.
- Details of zero or more optional conditions on the completion of the deal – *options/option*.
- Optional details of any payments additional to the principal economic details of the deal (e.g. brokerage fee, regulatory payments etc.) – *additionalPayments*.
- Zero or more optional instructions for settlement and confirmation – *instructions*.

4.1 The *dealHeader* Component

The *dealHeader* holds information about a deal which is common to the underlying trades and options.

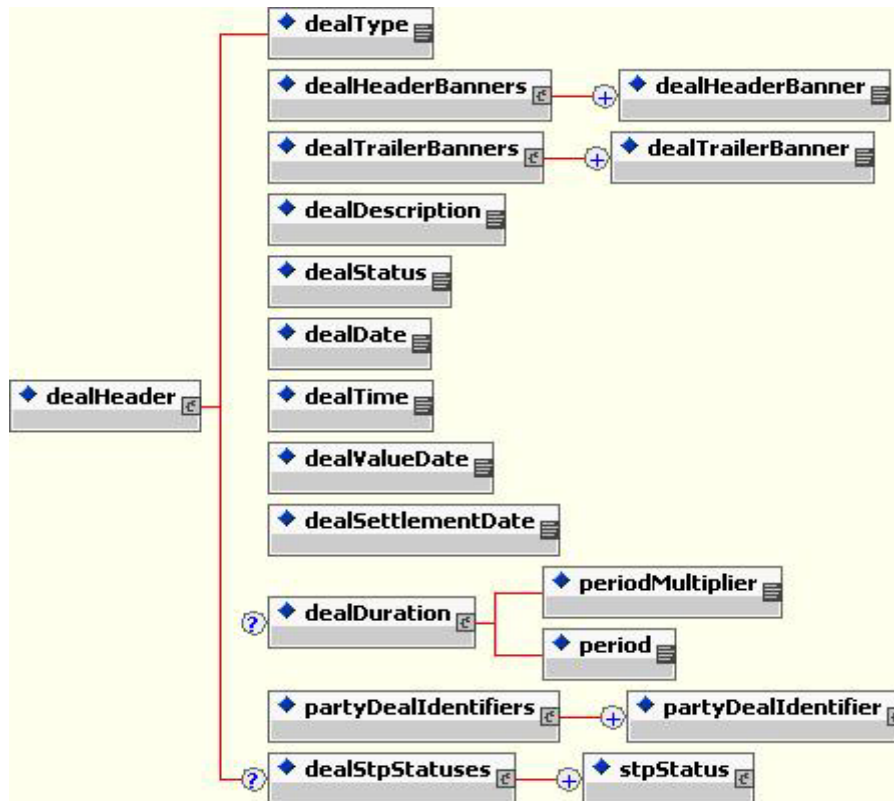

Figure 8 - Graphical representation of a deal header

It contains

- The type of the deal for quick discovery of the deal characteristics – *dealType*.
- One or more textual banners for the header – *dealHeaderBanners/dealHeaderBanner*.
- One or more textual banners for the trailer – *dealTrailerBanners/dealTrailerBanner*.
- A textual description of the deal – *dealDescription*.
- The status of the deal – *dealStatus*.
- The date and time of deal creation – *dealDate* and *dealTime*.
- The date when the transaction has monetary value – *dealValueDate*.
- The date for monetary settlement of the deal – *dealSettlementDate*.
- An optional duration for which the deal is to be in force – *dealDuration*.
- One or more identifiers by which the various parties to the deal refer to it – *partyDealIdentifiers/partyDealIdentifier*.
- Zero or more flags holding the STP status of the deal *dealSTPStauses/dealSTPStaus*.

The *partyDealIdentifiers/partyDealIdentifier* Component

The *partyDealIdentifier* holds the information that a particular party to the trade uses to identify the deal.

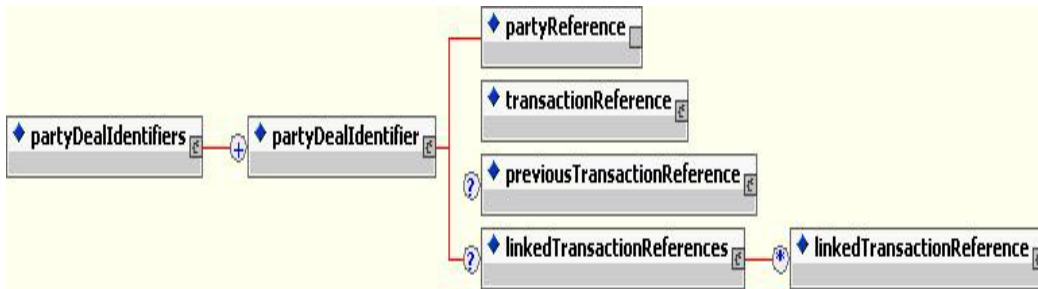

Figure 9 - Graphical representation of deal identifiers for parties

It contains

- A reference to the relevant party – *partyReference*.
- The current transaction reference for the party – *transactionReference*.
- An optional previous transaction reference – *previousTransactionReference*.
- Zero or more optional references to any linked transactions – *linkedTransactionReference*.

4.1.1.1. The transactionReferences Component

The *transactionReference* component holds information about the reference that a party to a transaction uses to identify it.

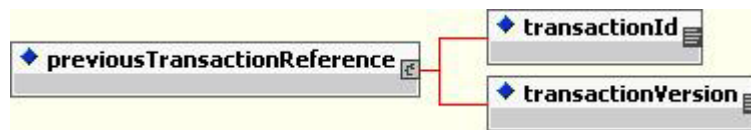

Figure 10 - Graphical representation of transaction references for parties

It consists of

- A transaction identifier – *transactionId*.
- A transaction version to support modified transactions – *transactionVersion*.

The dealDuration Component

The *dealDuration* contains the duration for which the deal is valid.

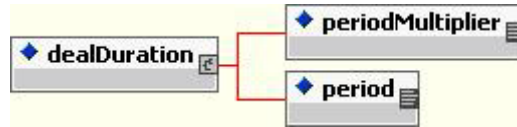

Figure 11 - Graphical representation of the duration of a deal

It consists of

- A period definition – *period*.
- A multiplier, which combined with the period, results in the actual duration – *periodMultiplier*.

The dealSTPStatuses/dealSTPStatus Component

The *dealSTPStatuses/dealSTPStatus* contains the STP status of the deal.

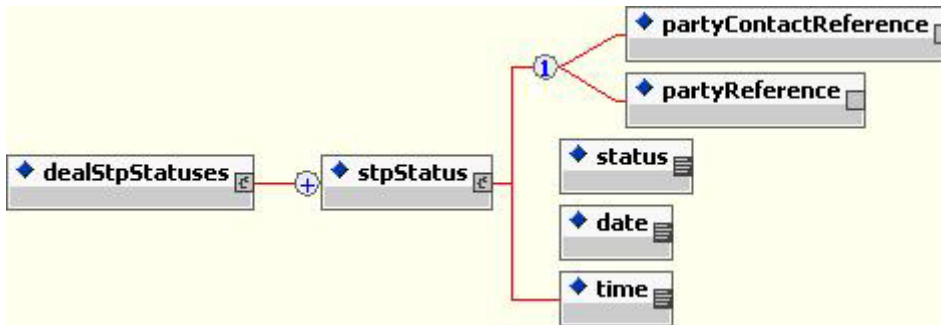

Figure 12 - Graphical representation of the STP status of a deal

It contains information about

- The party to which the deal STP status relates to – *partyContactReference* or *partyReference*.
- The STP status itself – *status*.
- The date and time of the status – *date*, *time*.

4.2 The trades/trade Component

The *trades/trade* component in BML contains the economic information necessary to execute and confirm that trade. This includes a product definition, any optional components, any payments to be made to parties other than the principal parties (e.g. brokerage fee, clearing charges etc.) and any manual instruction.

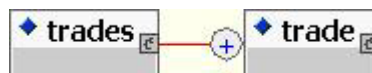

Figure 13 - Graphical representation of a set of trades

4.3 The *options*/*option* Component

The *option* component in BML contains the information associated with an option granted by one party to another in order to be able to change the completion characteristics of a transaction.

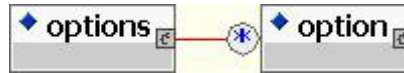

Figure 14 - Graphical representation of a set of options on the terms of a transaction

4.4 The *additionalPayments*/*additionalPayment* Component

The *additionalPayments*/*additionalPayment* component contains information about payments such as brokerage paid to third parties which are not part of the economics of a transaction itself.

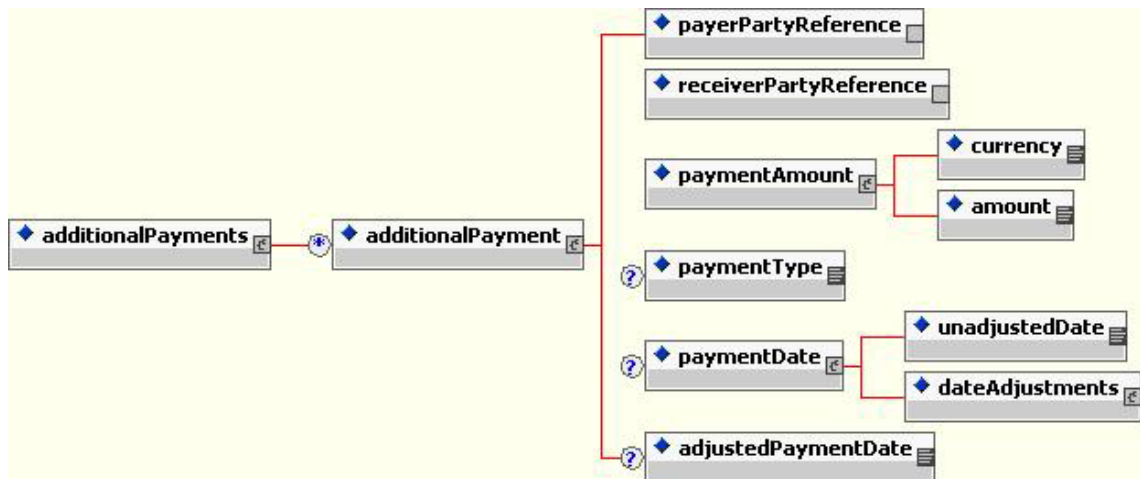

Figure 15 - Graphical representation of the additional payments for a transaction

It contains

- A reference to the party paying for the transaction – *payerPartyReference*.
- A reference to the party receiving payment for the transaction – *receiverPartyReference*.
- The payment amount itself – *paymentAmount*.
- An optional type of the payment – *paymentType*.
- The payment date, with information about how to adjust the date in the future with reference to holidays etc. – *paymentDate*.
- An optional textual unadjusted payment date. – *adjustedPaymentDate*.

The *paymentDate* Component

The *paymentDate* component holds information about ways to calculate a future payment date based on the supplied parameters.

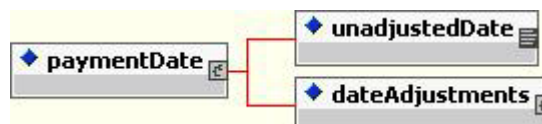

Figure 16 - Graphical representation of the payment date for a transaction

It contains

- A date unadjusted for business holidays etc. – *unadjustedDate*.
- Parameters for adjusting the date. – *dateAdjustments*.

4.4.1.1. The *dateAdjustments* Component

The *dateAdjustments* component holds information about ways to adjust a future date.



Figure 17 - Graphical representation of the date adjustments for a transaction

It contains

- An indication of the convention used for calculating a business day – *businessDayConvention*.
- A set of one or more business centres that are relevant to the transaction or a reference to the set elsewhere in the notification – *businessCenters* or *businessCenterReference*.

4.5 The *instructions/instruction* Component

The *instructions/instruction* component contains any instructions for settlement, confirmation etc. specified by any of the parties to the deal.

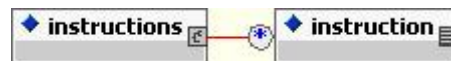

Figure 18 - Graphical representation of textual instructions for a transaction

It consists of

- A set of zero or more textual instructions for the transaction – *instruction*.

5 The *trades/trade* Component

A trade is an agreement between two parties to enter into a financial contract for exchanging products in return for a payment. The *trades/trade* component in BML contains the economic information necessary to execute individual transactions that are part of the overall transaction contained in a *deal* component.

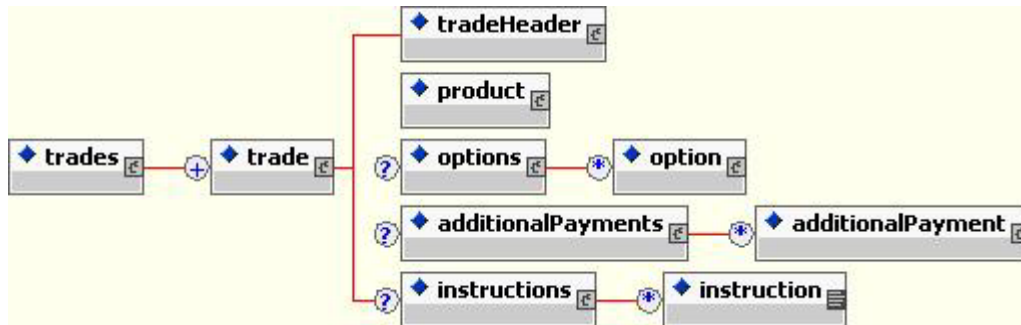

Figure 19 - Graphical representation of a trade

It contains

- Information common to all the components of an individual financial transaction – *tradeHeader*.
- A description of the product traded, where a ‘product’ is an abstract concept and is a place holders for actual financial products such as bonds, swaps, foreign exchange etc. – *product*.
- Details of zero or more optional conditions on the completion of the trade – *options/option*.
- Optional details of any payments additional to the principal economic details of the trade (e.g. brokerage fee, regulatory payments etc.) – *additionalPayments*.
- A set of zero or more textual instructions for the transaction – *instruction*.

5.1 The *tradeHeader* component

The information common across all the components of a trade is contained within the *tradeHeader* component.

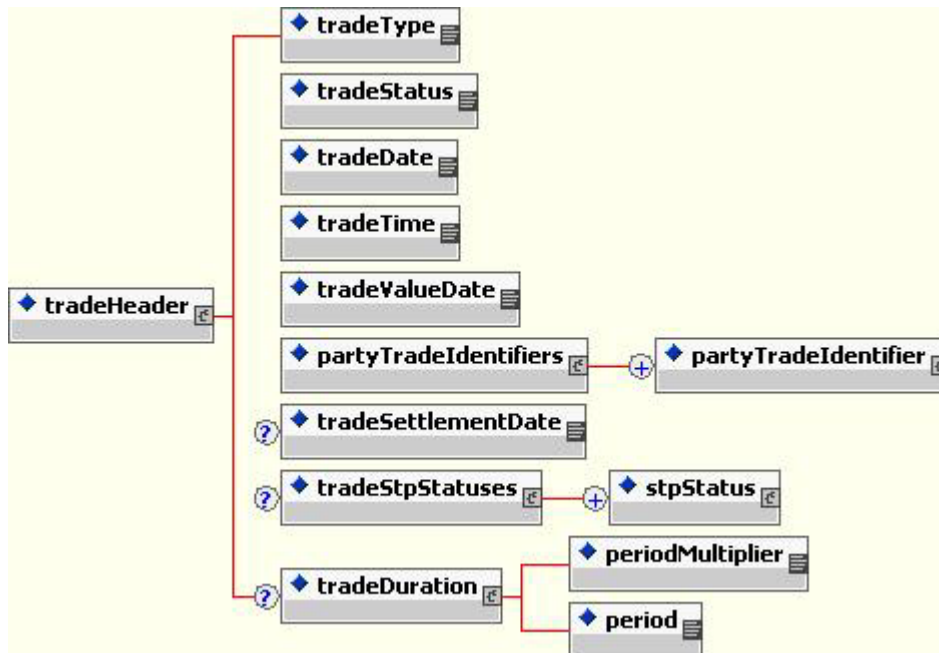

Figure 20 - Graphical representation of a trade header

It consists of

- The type of the transaction – *tradeType*.
- The status of the transaction – *tradeStatus*.
- The date and time, on which the transaction is agreed – *tradeDate* and *tradeTime*.
- The date on which the transaction starts accruing monetary value – *valueDate*
- One or more identifiers for the transaction – *partyTradeIdentifiers*/*partyTradeIdentifier*.
- An optional date for monetary settlement of the transaction – *tradeSettlementDate*.
- Zero or more flags holding the STP status of the transaction – *tradeSTPStauses*/*tradeSTPStaus*.
- An optional duration for which the trade is to be in force – *tradeDuration*.

The *partyTradeIdentifiers*/*partyTradeIdentifier* Component

The *partyTradeIdentifier* contains the information that a particular party to the trade uses to identify the trade.

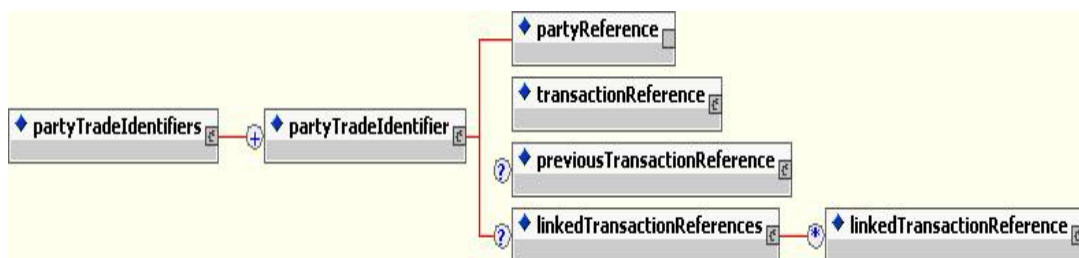

Figure 21 - Graphical representation of a trade header

It contains

- A reference to the relevant party – *partyReference*.
- The current transaction reference for the party – *transactionReference*.
- An optional previous transaction reference – *previousTransactionReference*.
- Zero or more optional references to any linked transactions – *linkedTransactionReference*.

The tradeSTPStatuses/tradeSTPStatus Component

The *tradeSTPStatuses/tradeSTPStatus* contains the STP status of the deal.

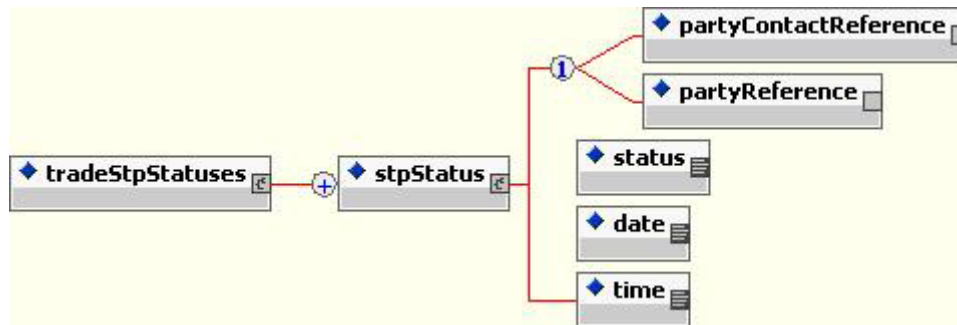

Figure 22 - Graphical representation of the STP status of a trade

It contains information about

- The party to which the trade STP status relates to – *partyContactReference* or *partyReference*.
- The STP status itself – *status*.
- The date and time of the status – *date* and *time*.

The tradeDuration Component

The *tradeDuration* contains the duration for which the deal is valid.

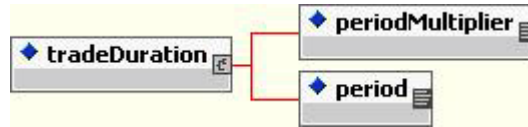

Figure 23 - Graphical representation of the duration of a deal

It consists of

- A period definition – *period*.
- A multiplier, which combined with the period, results in the actual duration – *periodMultiplier*.

5.2 The options/option Component

The *option* component in BML contains the information associated with an option granted by one party to another in order to be able to change the completion characteristics of a transaction.

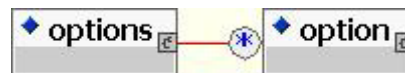

Figure 24 - Graphical representation of a set of options on the terms of a transaction

5.3 The additionalPayments/additionalPayment Component

The *additionalPayments/additionalPayment* component contains information about payments such as brokerage paid to third parties which are not part of the economics of a transaction itself.

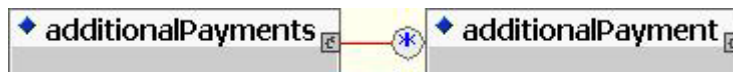

Figure 25 - Graphical representation of the additional payments

5.4 The instructions/instruction Component

The *instruction* component contains any instructions for settlement, confirmation etc. specified by any of the parties to the deal.

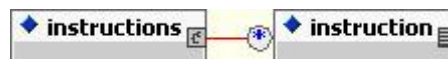

Figure 26 - Graphical representation of textual instructions for a transaction

6 The *options*/*option* Component

The *option* component in BML contains the information associated with an option granted by one party to another in order to be able to change the completion characteristics of a transaction.

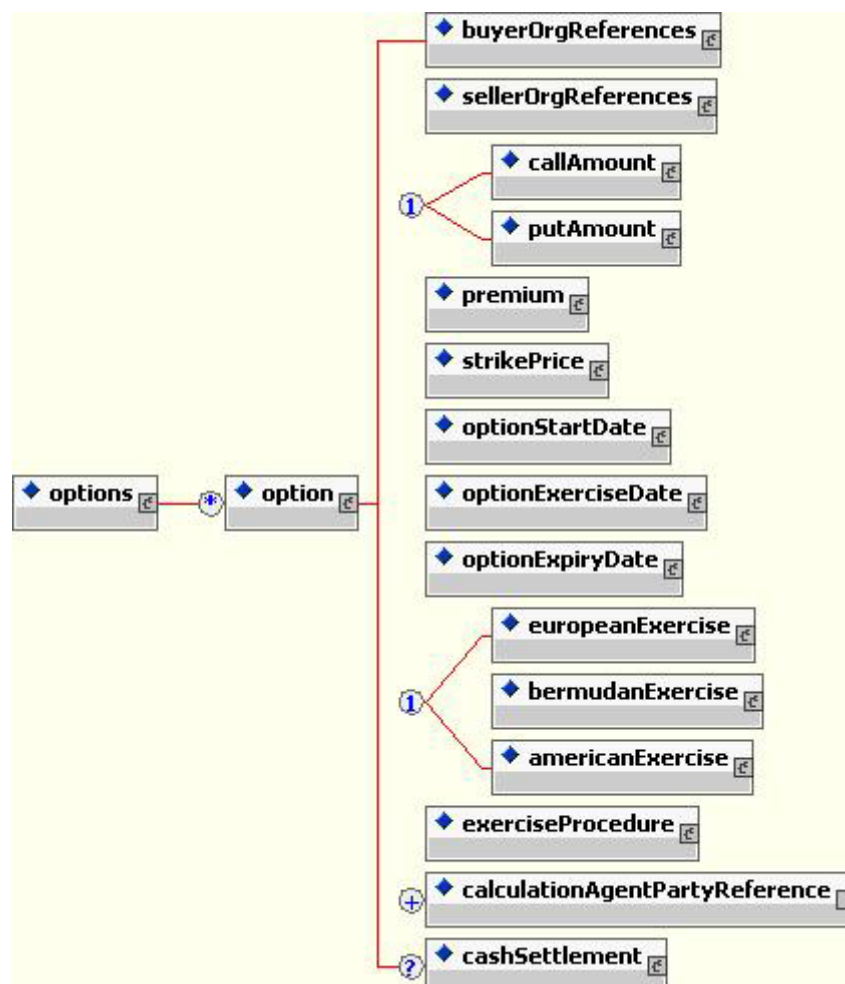

Figure 27 - Graphical representation of option information

It contains

- References to the buyer organisation of the option – *buyerOrgReference*.
- References to the seller organisation of the option – *sellerOrgReference*.
- The monetary amounts for the right to either ‘call in’ the option by the buyer or to “put” it by the seller – *callAmount* or *putAmount*.
- The premium to be paid by the buyer to the seller – *strikePrice*.
- The date at which the option is deemed to start – *optionStartDate*.
- The date at which the option can be exercised – *optionExpiryDate*.
- The exercise type of the option (European, American, Bermudan etc.) – *europeanExercise* or *bermudanExercise* or *americanExercise*.
- Details of the procedure for the exercise of the option – *exerciseProcedure*.
- References to one or more calculation agents defined elsewhere in the notification – *calculationAgentPartyReference*.
- Details of optional cash based settlements – *cashSettlement*.

6.1 The *buyerOrgReferences* and *sellerOrgReferences* Components

The organization references for a party to a financial transaction are listed in *buyerOrgReferences* and *sellerOrgReferences* components. These include references to the party as well as any people that might be involved in the transaction. The references are to the party or contact information defined elsewhere in the document and are named according to the roles of the various entities in the transaction.



Figure 28 - Graphical representation of organisation references

They consist of

- A reference to the party responsible for executing the transaction – *executingPartyReference*.
- A reference to the trading party of the transaction – *tradingPartyReference*.
- An optional reference to the party billing for the transaction – *billingPartyReference*.
- An optional reference to the party acting as an agent for the transaction – *agentPartyReference*.
- An optional reference to the contact person from the party acting as broker in the transaction – *brokerContactReference*.
- An optional reference to the contact person from the trading party of the transaction – *tradingContactReference*.
- An optional reference to the contact person from the party billing for the transaction – *billingContactReference*.
- An optional financial accounting cost centre of the agent party – *agentCostCentreId*.
- An optional identifier for the trading book – *tradingBookId*.

6.2 The *premium* Component

The *premium* component in BML contains the information regarding the premium payment on an option.

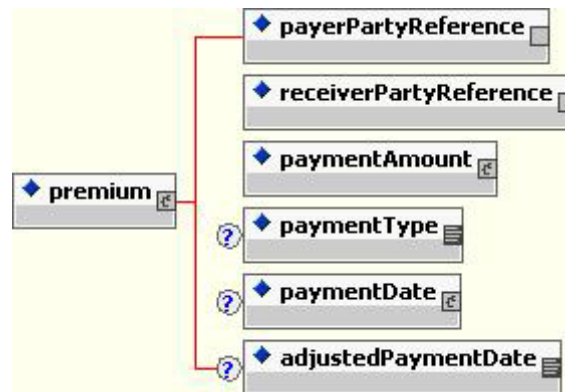

Figure 29 - Graphical representation of option premium

It contains

- A reference to the party paying the premium – *payerPartyReference*.
- A reference to the party receiving the premium – *receiverPartyReference*.
- The monetary amount of the premium – *paymentAmount*.
- The optional type of the payment – *paymentType*.
- The optional date of the payment adjustable for business calendars – *paymentDate*.
- The optional adjusted date of the payment – *adjustedPaymentDate*.

6.3 The *optionStartDate* Component

The *optionStartDate* component in BML contains the information regarding the starting date of an option. It is specified as either an adjustable date or a relative date.

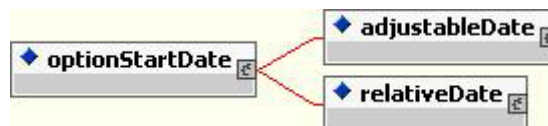

Figure 30 - Graphical representation of option start date

An adjustable date is specified as an unadjusted date and the parameters necessary to calculate the adjusted dates based on the business day convention and a set of business centres or a reference to such a set. A relative date is specified in terms of the date on which the calculated date is based on, a business day convention, the interval used to calculate the offset to the base date and a set of business centres.

6.4 The *optionExerciseDate* Component

The *optionExerciseDate* component in BML contains the information regarding the date when an option can be exercised. It is specified as either an adjustable date or a relative date.

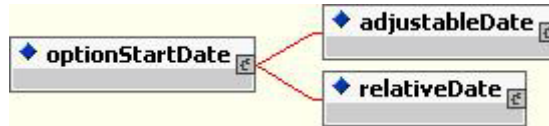

Figure 31 - Graphical representation of option exercise date

6.5 The *optionExpiryDate* Component

The *optionExpiryDate* component in BML contains the information regarding the date when an option is deemed to have expired. It is specified as either an adjustable date or a relative date.

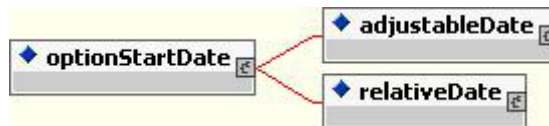

Figure 32 - Graphical representation of option expiry date

7 The *product* Component

The *product* component specifies the financial instrument being traded. This component captures the economic details of the trade. Because of the complexity of the OTC product domain such as Interest Rate Derivatives that BML covers, composing these products from various building blocks is a key aspect of the design approach.

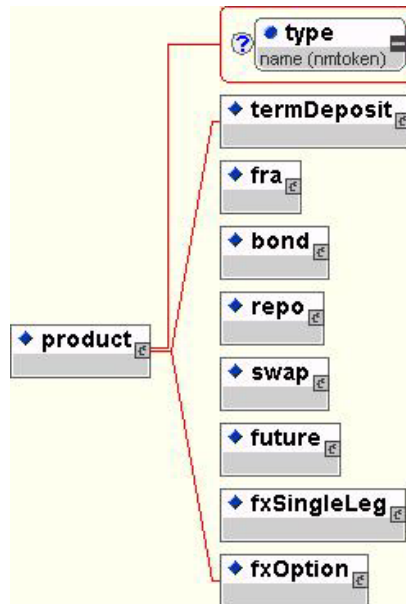
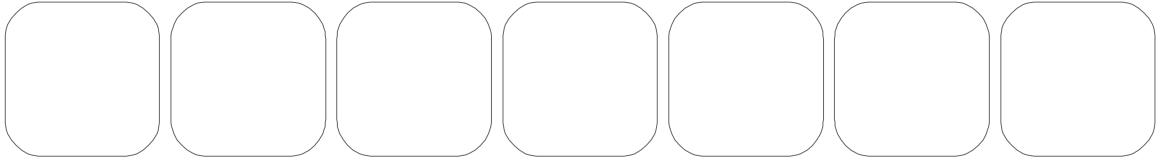

Figure 33 - Graphical representation of a product

The individual product definitions are defined in individual specifications for these products.

Document Ends



Tullett Liberty
Cable House,
54-62 New Broad Street,
London,
EC2M 1ST
ENGLAND
www.tullib.com

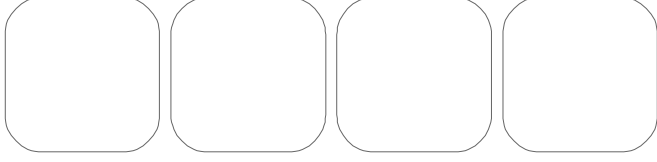
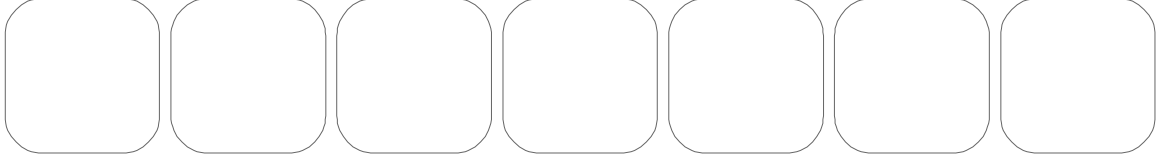
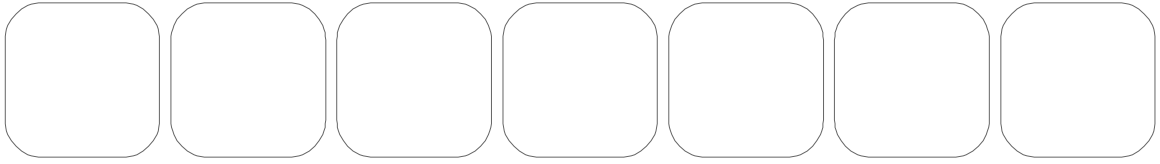
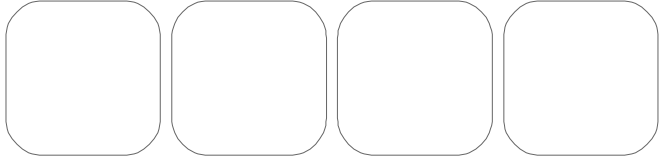
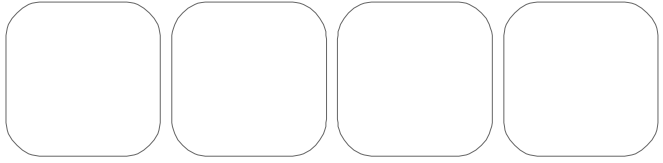

Tullett Liberty